

REVISIONS

| NO. | DATE | BY | REMARKS |
|-----|------|----|---------|
|     |      |    |         |
|     |      |    |         |
|     |      |    |         |
|     |      |    |         |
|     |      |    |         |
|     |      |    |         |
|     |      |    |         |
|     |      |    |         |
|     |      |    |         |
|     |      |    |         |

NOTES

1. IN CONCRETE PAVEMENTS, REMOVE SECTIONS TO EXISTING JOINTS, OR NEW SAW CUT JOINTS AT MID-SLAB, THAT ARE IN GOOD REPAIR. IN DAMAGED CONCRETE, THE LIMITS OF REMOVAL SHOULD BE DETERMINED IN THE FIELD BY CITY INSPECTIONS.

NOT ACCEPTABLE

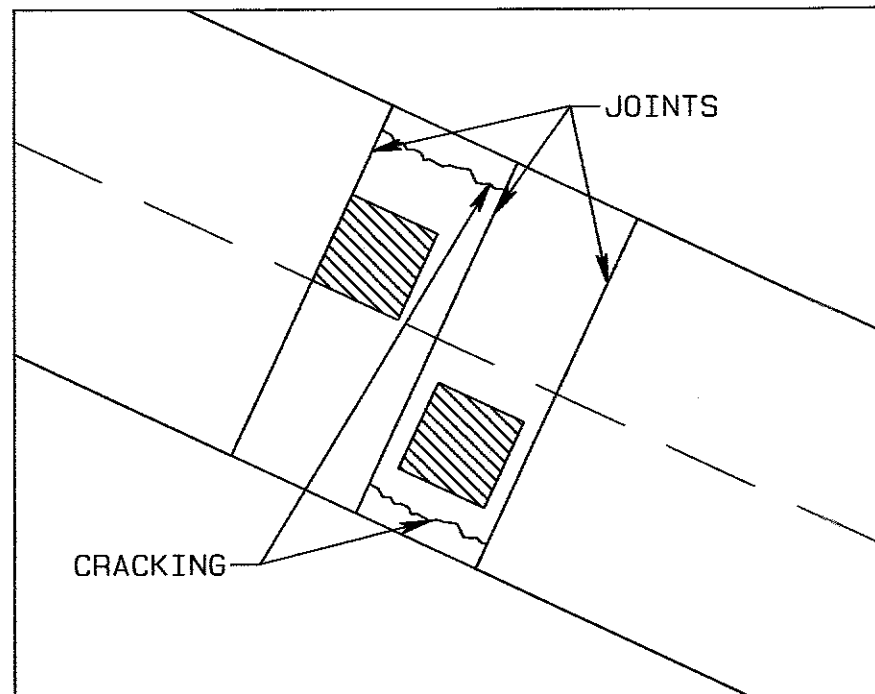

ACCEPTABLE

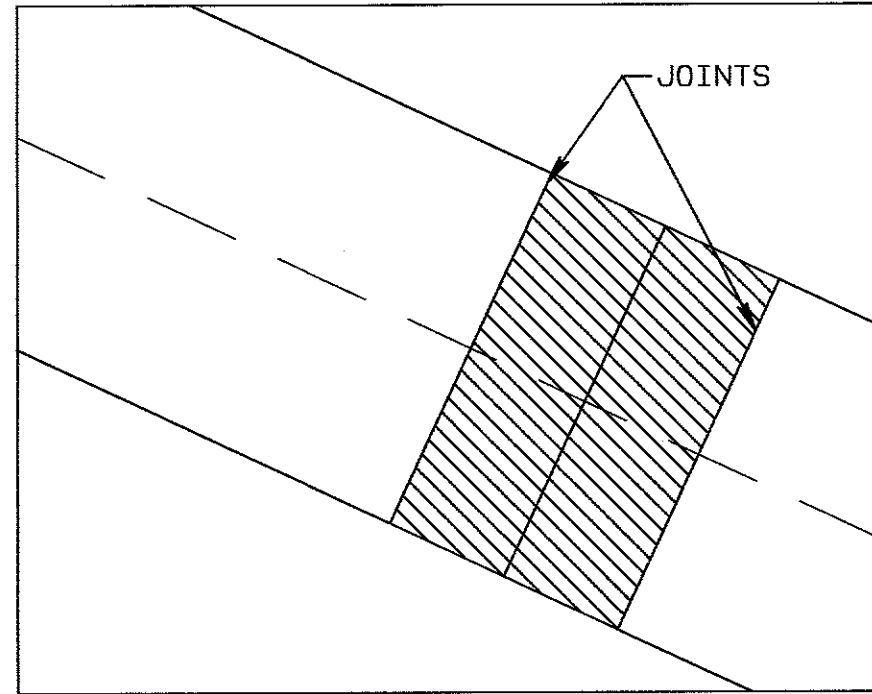

NOT TO SCALE

CITY OF MEMPHIS  
DIVISION OF ENGINEERING

DESIGN STANDARD  
FOR  
CONCRETE PAVEMENT REPAIR

*Chae An*  
CIVIL DESIGN ENGINEER

12-11-19  
DATE

*WE* 12/11/19  
CITY ENGINEER

DATE